

# COOKBOOK *for*



# GTX



> A reference guide for all GTX Series users

V1.0

**brother**  
at your side



For further information around the GTX  
please visit us on the following website:

[www.brothergtx.com](http://www.brothergtx.com)

# ENVIRONMENTAL CONDITIONS

## > Mandatory Temperature & Humidity Requirements :

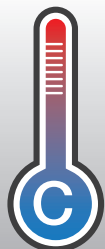
Required to keep the warranty! Temperature & Humidity are recorded in the Log file!

TEMPERATURE		HUMIDITY	
	MIN <b>18°</b>	% 	MIN <b>35</b>
	MAX <b>30°</b>		MAX <b>85</b>

*If not enough, please install a humidifier !*

Go to the menu: **Maintenance** > **Temperature/Humidity info** > 

> If temperature too cold, printer will switch automatically to Low-Temp Mode and reduce the speed!

## PRE-TREATMENT RATIO

1 Liter	2 Liters	3 Liters
<b>Pre Treatment Solution</b>	<b>Distilled Water</b>	<b>PreTreatment Ready to Use</b>
+	=	
1,25 Kg	2 Kg	3,25 Kg

⚠ This mixing ratio might vary due to the type of garment which is used.

## PRE-TREATMENT QUANTITY on T-SHIRTS

<b>Pre Treatment Ready to use Quantity</b>	<b>DARK Ts</b>	=	<b>30 Grams</b>
	<b>MEDIUM Ts</b>	=	<b>24-27 Gr.</b>
	<b>LIGHT Ts</b>	=	<b>14-17 Gr.</b>

 Don't forget that you have to define a surface of **14 X 16 inches** (35 X 40 cm) with your Pre-Treatment machine **to weight** with a **scale** after applying the PT liquid on a T-shirt!

> For example, on a Schulze PTM, you should enter a length of 36 cm and the full width with 4 nozzles will be 40 cm!

# HEAT PRESS SETTINGS for Pre-Treatment DRYING



**Pre Treatment**  
1/2 distilled water

**35**  
Seconds

**180°C**  
**360°F**

**5 - 5,5**  
Bars  
**75 - 80**  
PSI

✂ Use **Silicon sheet** on the heat press to cover the pre-treatment and **clean** the surface every 5 T-shirts!

# HEATPRESS & TUNNEL DRYER SETTINGS for INK CURING



**HEATPRESS**  
**Ink Curing**

**35**  
Seconds

**180°C**  
**360°F**

**0,7 - 1,4**  
Bars  
**10 - 20**  
PSI

**TUNNEL DRYER**  
**Ink Curing**

**3,30**  
Minutes

**160°C**  
**320°F**

✂ Check the **Real Temperature** with a **Probe** or with **Strips** to be sure that you are safe for washability!

## VERY IMPORTANT



The Brother **GTX** should **ALWAYS** be left with Power **ON**



**NEVER** shut **OFF** the printer except if requested by the display informations!  
Power is requested to perform the needed recirculation of the inks from time to time.

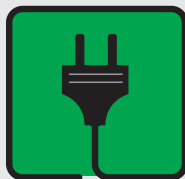

**NEVER POWER OFF THE PRINTER!**



## DAILY AGITATION OF WHITE INK

> Perform the procedure shown below if the message "Remove the white ink cartridge and shake it" is displayed before starting operation.

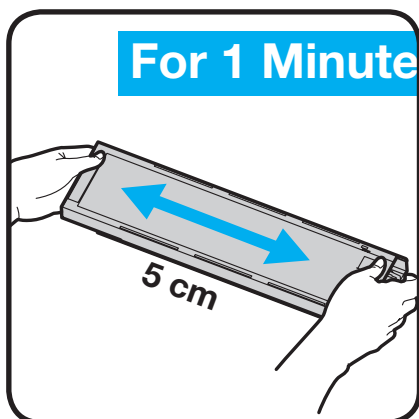

Take out the white ink cartridge from the printer.  
Shake the cartridge horizontally **100** times side by side to stir the white ink.

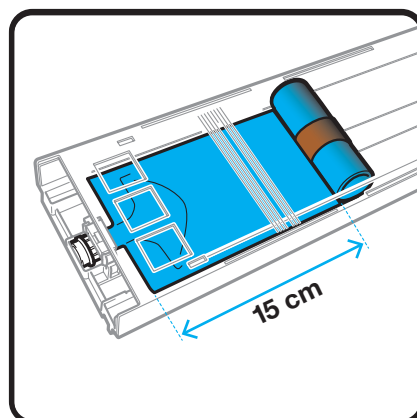

When the remaining ink level becomes approximately **15 cm**, shake the cartridge with its **cover open** and with the ink pouch slightly winded, to make the ink easier to stir.

> Repeat the same process on the other white ink cartridge! On the operation panel, press  and the White Ink refilling will be performed automatically by the printer!



## POUCH REPLACEMENT - VERY IMPORTANT !

Open the cartridge's lid on a **flat surface** and remove the empty pouch.  
Unpack carefully a new ink pouch from its shipping carton.

**Push** the **green tip end** of the ink pouch into the cartridge until it **clicks** into place.  
Straighten the ink pouch to align it with the gutter of lid of cartridge, and mount in position inside the metal spring by pulling it with your hand.

If the edge of the ink pouch is bent or undulating significantly, make it **straight** and **flat** with your hand **to avoid wrinkles**.

Place the pouch in a straight alignment with the cartridge. Align lines with each other!

 Close the lid, verify if the spring is rolling to the front. Place the cartridge at around **45°** and **push** on the **2 upper metallic latches** to add a bit more tension on the ink pouch.

Attach a shelf life **sticker**

09. 2019 XXXX
------------------

 included with ink pouch onto the front of the cartridge.

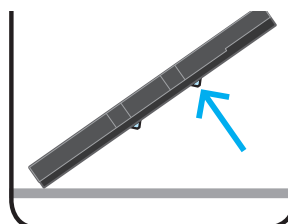
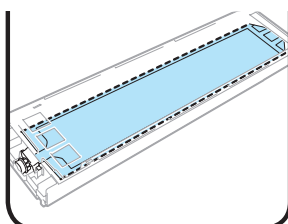
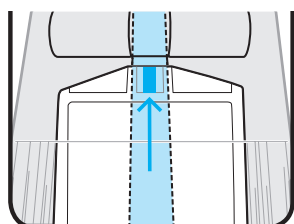
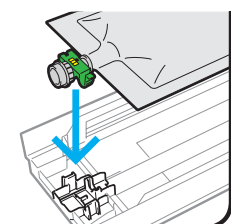

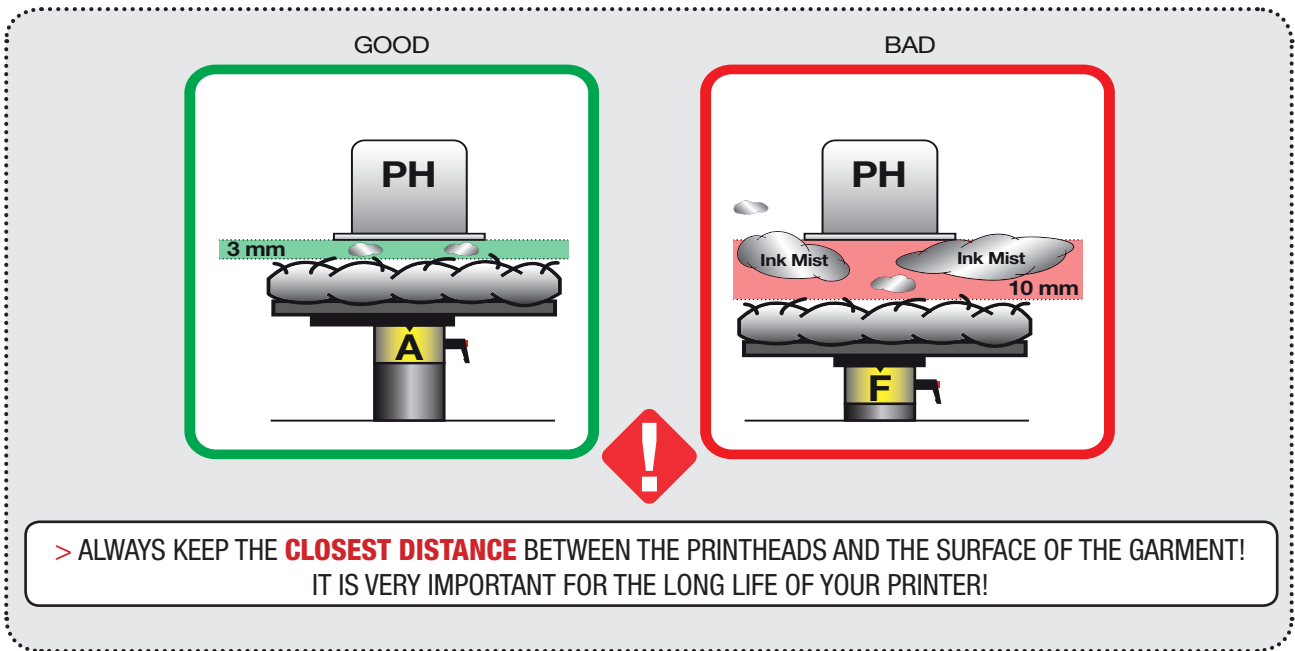

> ALWAYS KEEP THE **CLOSEST DISTANCE** BETWEEN THE PRINTHEADS AND THE SURFACE OF THE GARMENT! IT IS VERY IMPORTANT FOR THE LONG LIFE OF YOUR PRINTER!

## ADJUSTING THE HEIGHT OF THE PLATEN

To provide an optimum printing image quality when a thicker textile is used, you need to **adjust** the platen's height related to the **thickness of the textile**.

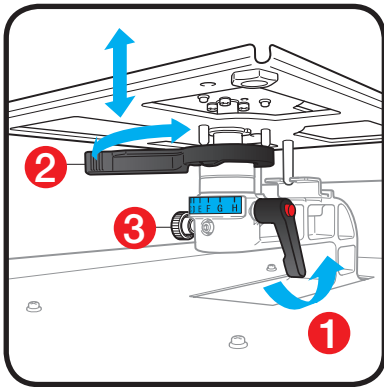

To adjust the platen height, loosen the **Platen Fixing Lever ①** and move the **Platen Height Adjustment Lever ②** to a lower position. Re-tighten the Platen Fixing Lever if you are happy with new distance. Flatten down all the wrinkles of the fabric.

To check if new textile is not detected by the **sensor**, push the button **①** and **repeat** the process **if needed!** If you need to go down further more, remove 1 or 2 collars, loosen the knob **③** and push down the platen bearing by 1 or 2 steps.

Re-attach everything and tighten again the **Platen Fixing Lever**

 > Don't forget to **bring back** the platen to the **A** position printing on thicker material! > Always leave the knob **③** tighten after changing position!

> if you have to print above hem and seams, go for **UNI-directional** printing to keep quality!

## GTX MAINTENANCE OVERVIEW

 There are several maintenance procedures that **must be performed** on a daily, weekly, or prompted basis in order to keep your printer performing **properly**.

This short guide describes the maintenance procedures that must be performed.

> Please see the **Instruction Manual** for each specific maintenance procedure for step by step instructions.



Please also check useful videos at <https://www.youtube.com/user/BrotherGTSeries/videos>



## > NOZZLE TEST

! TO BE DONE *EVERY* WORKING DAY

You have to print a nozzle test for White & CMYK **every morning** before using the printer. It is the only way to know the status of the nozzles in the machine !

## > HOW TO DO A NOZZLE TEST ?

NZC

Always place the **Platen** at level **A**

Menu > Test Print > Nozzle Check CMYK >  to check colors on a white paper sheet

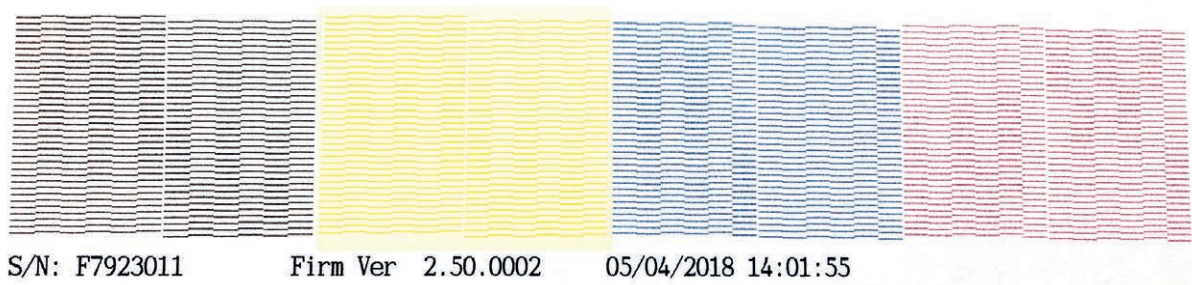

NZC

Repeat the same procedure to perform a nozzle test of the **White** printhead

Menu > Test Print > Nozzle Check White >  to check White on a black paper sheet or inkjet plastic sheet

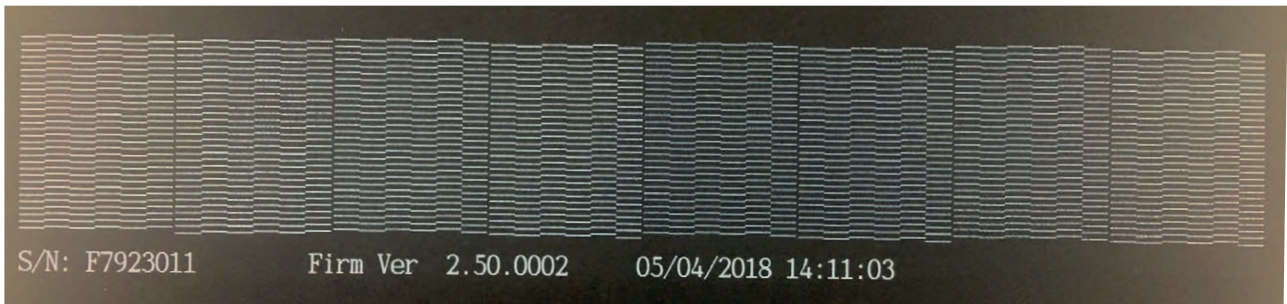

> If not all nozzles are firing, start a **Head Cleaning** to open the closed nozzles!

## > HOW TO DO A PRINT HEAD CLEANING?

PHC

If only a few nozzles are missing, select **Head Cleaning** > **Powerful Cleaning** ... and select **PH + OK**

If more than 10 nozzles, select **Head Cleaning** > **Super Cleaning** ... and select **PH + OK**

> Perform a new Nozzle Test to check the result and redo if not **ALL** nozzles are firing!

## > WEEKLY MAINTENANCE PROCEDURES



To achieve a good **weekly maintenance** you will have to do the following actions:

### WEEKLY MAINTENANCE

+ Suction Cap Cleaning

+ Exhaust Cleaning

+ Wiper Cleaning

+ Nozzle Guards Cleaning



> Always use this menu to perform cleanings or replace parts :

Menu > Maintenance > Maintenance Part Clean/Replace >  and follow instructions on the display

## > Suction Cap & Exhaust Cleaning

TO BE DONE **EVERY WEEK**

The black silicon lips of the two cappings should be cleaned with the **Cleaning Stick R** dipped in **Cleaning Solution**.

It is necessary to remove the built-up of the remaining ink staying on the edges of the cappings. It will prevent air leakage and keep the good suction of the pumps!

Be careful not to touch the foam! Keep it flat!

The **four extrusion lances** (see in the blue circle...) and the **hole** sitting on the side of the capping at the **Exhaust** position need also to be cleaned and free of dried ink.

**Always** clean first the hole at the front and go backward while cleaning the **lances**!

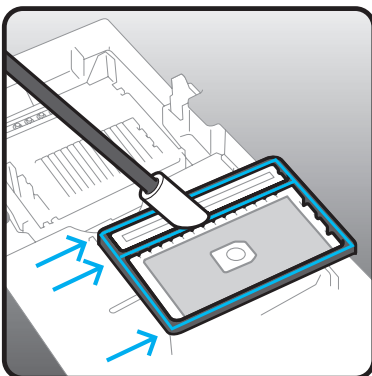
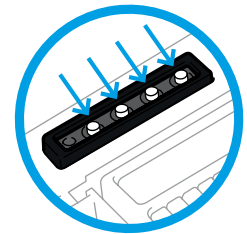

Suction Cap Cleaning

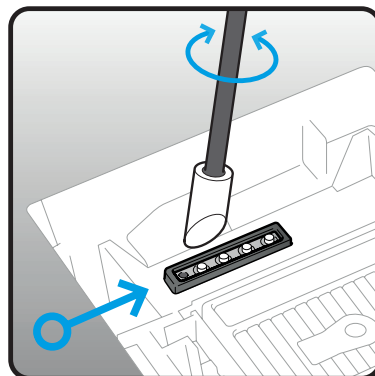

Exhaust Cleaning

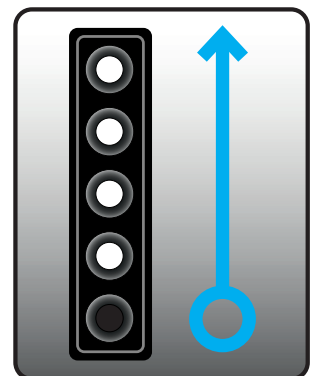

Direction to clean

## > Wiper Cleaning

! TO BE DONE **EVERY WEEK**

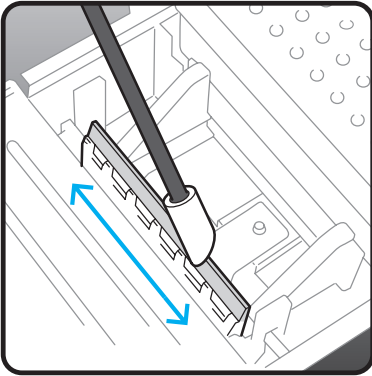

Both white plastic wipers [White & CMYK] should be cleaned on **both sides** and **top** with the **Cleaning Stick R** dipped in **Cleaning Solution**.

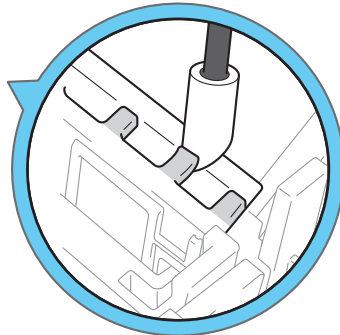

Use the tip of the **Cleaning Stick R** to clean under the teeth of the wiper holder and remove the dried ink.

Be sure to use the Cleaning stick R separately for **white** ink and **color** ink!

## > Nozzle Guards Cleaning

! TO BE DONE **EVERY WEEK**

Wipe clean the 2 nozzle guards **1** & **2** with the **Clean Stick R** dipped in **Cleaning Solution**.

Be sure **not** to touch the **nozzle surface 3** at all!

Manually move the carriage to such a position that you can perform the cleaning with ease.

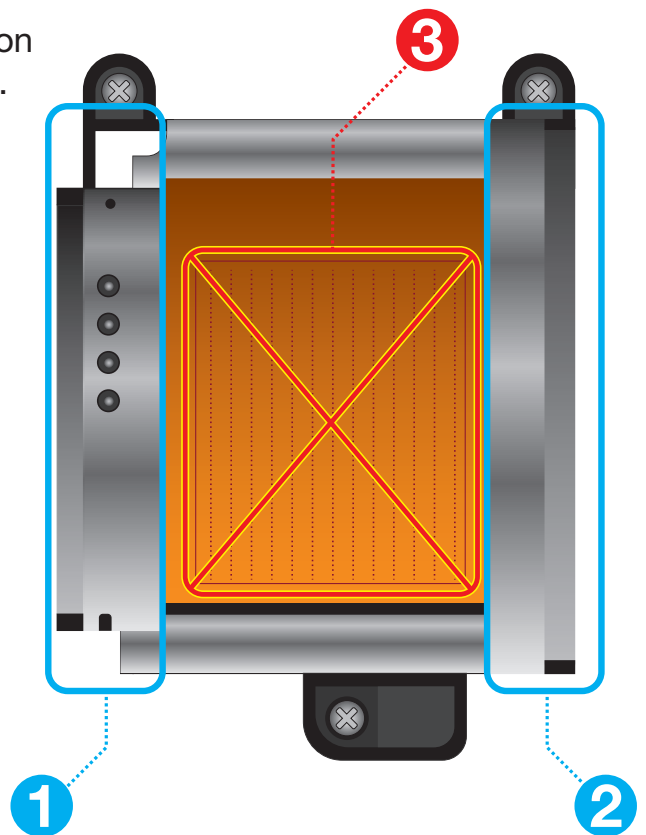
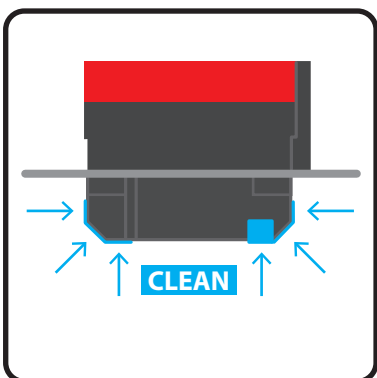
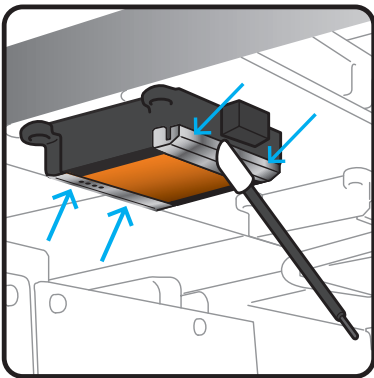

> The remaining Cleaning Solution from the Cleaning Cup should be emptied in the **Waste Tank** below the printer!



## > MAINTENANCE PARTS CLEANING & REPLACING PROCEDURES

**WARNING**   **ERROR**

In case of Warning/Error messages please follow the following procedures:

> Always use this menu to perform cleanings or replace parts :

Menu > Maintenance > Maintenance Part Clean/Replace >  and follow instructions on the display



## > WIPER CLEANER REPLACEMENT

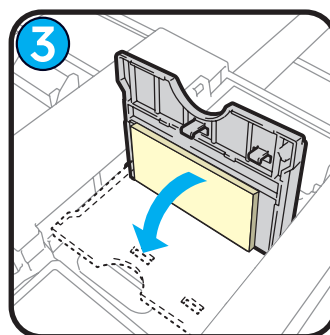
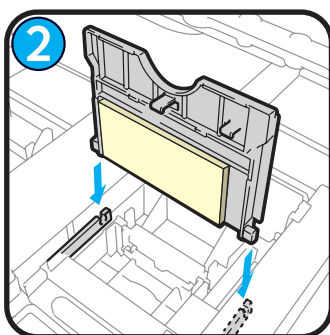
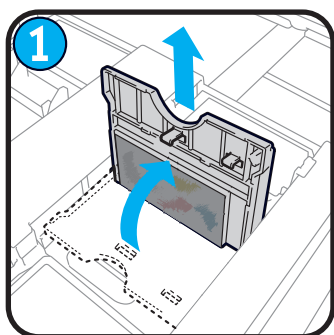

Simply remove the old **Wiper Cleaner** by lifting it up. Replace with a new one.

## > FLUSHING FOAM REPLACEMENT

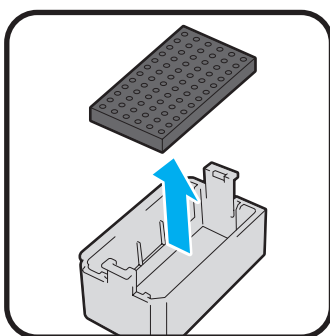
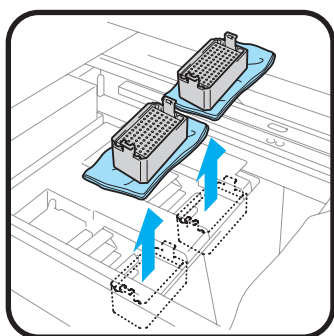

Lift up the **flushing receivers** and place them on cleaning paper to avoid dripping ink.

Remove **Flushing Foams** and clean the holes of the 2 receivers.

Install new Foams and put back the receivers at their original location.

Clean also under the receivers place!

## > FAN FILTER REPLACEMENT

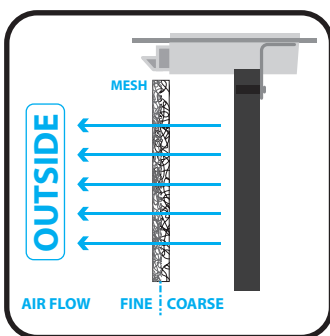
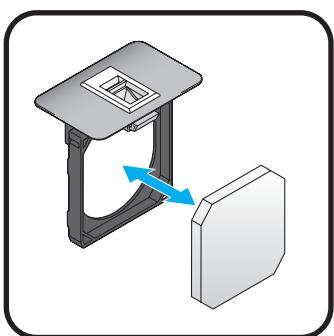

Extract the 2 filter holders from the back of the machine.

Mount a **new Fan Filter** in each black frames.

Coarse mesh surface in direction of the inner side of the printer and fine mesh surface in direction of the outside of the printer.



## ADDITIONAL WEEKLY MAINTENANCE



**Visual inspection** is important to keep your printer up and running. Verify all the moving parts of the machine and also check for leakage of ink.



Please follow also all the instructions that could appear on the **display** of the printer!

When you see a yellow number push the **key** to know what you have to perform to erase the **Error/Warning** message.



## INTERNAL CLEANING OF PRINTER

> If the inside of your printer is covered with **ink mist**, perform a **cleaning!**



> Always use this menu to perform cleanings or replace parts :

**Menu** > **Maintenance** > **Maintenance Part Clean/Replace** > and follow instructions on the display

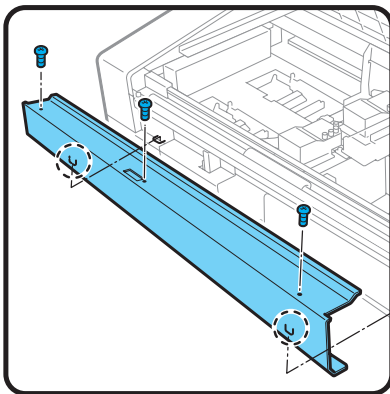

Remove 3 **Screws** to remove the **Encoder Cover**.

With the **Clean Stick R** dipped in **Cleaning Solution**, wipe away the stains on the **3 Carriage Rollers**. Move the carriage from side to side to wipe all around the 3 rollers completely.

Clean the **Carriage Guide Shaft** and the **3 sides** [upper, front, and lower] of **Roller Guide** with a non-fuzzy cloth moisten with a small amount of isopropyl **alcohol** [95°]

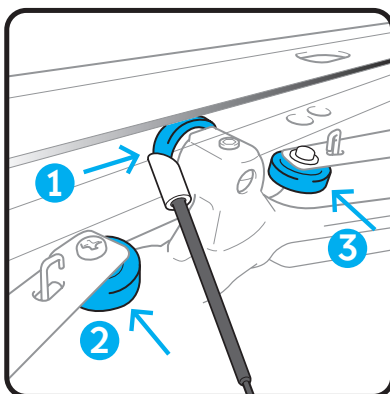

**Do not** use alcohol on other parts than the carriage guide shaft and the roller guide!

Apply a proper amount of **Molykote 30 Grease** onto the **Carriage Guide Shaft** only [never on the Roller Guide!]

Remove 3 screws to take out the encoder metal cover. With your non-fuzzy cloth moisten with **alcohol**, clean carefully both side of the **Encoder Strip**

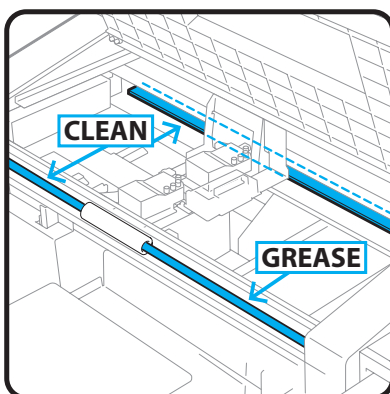

Perform a **CR Speed Adjustment**.

*Menu > Printer Setting > CR Speed Adjustment > OK*

Print out a **Nozzle Check** pattern.

## WHEN NOT USING PRINTER FOR LONG PERIOD OF TIME



-  When the printer will not be used for a prolonged period of time, take appropriate procedures before storing the printer depending on storage period or condition.
- > **DO NOT** turn the printer **OFF**, otherwise, the printer may be damaged.

### > WITHIN 2 WEEKS

The printer can be used through normal procedure after the storage period, by performing the following maintenance tasks:

- Please empty the **waste ink** in the **waste ink tank**.
- Check the amount of **Cleaning Solution** in the cleaning liquid **tank**, and refill the tank when its amount is below the proper level.
- Stir the white ink if a white ink cartridge stirring message is displayed on the operation panel screen.
- Print out a **Nozzle Check** pattern.

### > FOR MORE THAN 2 WEEKS

When storing the printer for **more** than two weeks, cleaning of the **Nozzle Guard**, **Wiper** and **Exhaust Cap** should be performed.

Same procedure as above **plus**:

- If a non-firing nozzle is found, perform **Head Cleaning** and run the **Nozzle Check** pattern print, and verify the result again.

## INK & SOLUTIONS STORAGE



CMYK & White inks, Cleaning Solution, Maintenance Solution & Pretreatment Solution should be stored at a temperature range between 0° and 40°

> **Be careful NOT to go below Zero degree !**

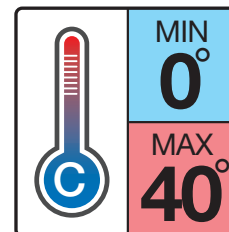

## HOW TO EXTRACT A LOG FILE FROM THE PRINTER?



Switch on the printer and insert a **USB stick**

Go to the menu: **Maintenance** > **Log copy to USB** > 



# INK & CONSUMABLES

## GTX Ink & Consumables

	Description of product	Product Code	Prize/Unit*
<b>INK POUCHES</b>	<b>C</b> Cyan Ink Pouch 500cc [GCX-4C50]	BGCX40C05000012	
	<b>M</b> Magenta Ink Pouch 500cc [GCX-4M50]	BGCX40M05000012	
	<b>Y</b> Yellow Ink Pouch 500cc [GCX-4Y50]	BGCX40Y05000012	
	<b>K</b> Black Ink Pouch 500cc [GCX-4K50]	BGCX40K05000012	
	<b>W</b> White Ink Pouch <b>2 x 500cc</b> [GCX-4W50]	BGCX40W05000012	
<b>LIQUIDS</b>	<b>CS</b> Cleaning Solution 1,9Kg [GCX-4E02]	BGCX40E002K0052	
	<b>MS</b> Maintenance Solution Pouch 700cc [GCX-4S70]	BGCX40S07000012	
	<b>PT</b> PreTreatment Liquid 5Kg-4L [GCX-4P05]	BGCX40P005K0042	
<b>PARTS</b>	Wiper Cleaner [2 pieces in the box]	SB6673001	
	Flushing Foam [2 pieces in the box]	SB7006001	
	Fan Filter [2 pieces in the box]	SB7007001	
	Cleaning Sticks R [50 pieces in the box]	SB7008001	



## NOTES



## CONTACT DETAILS OF YOUR BROTHER DEALER

Company Name:

Representative:

Email address:

Phone number: